

passion  
for precision

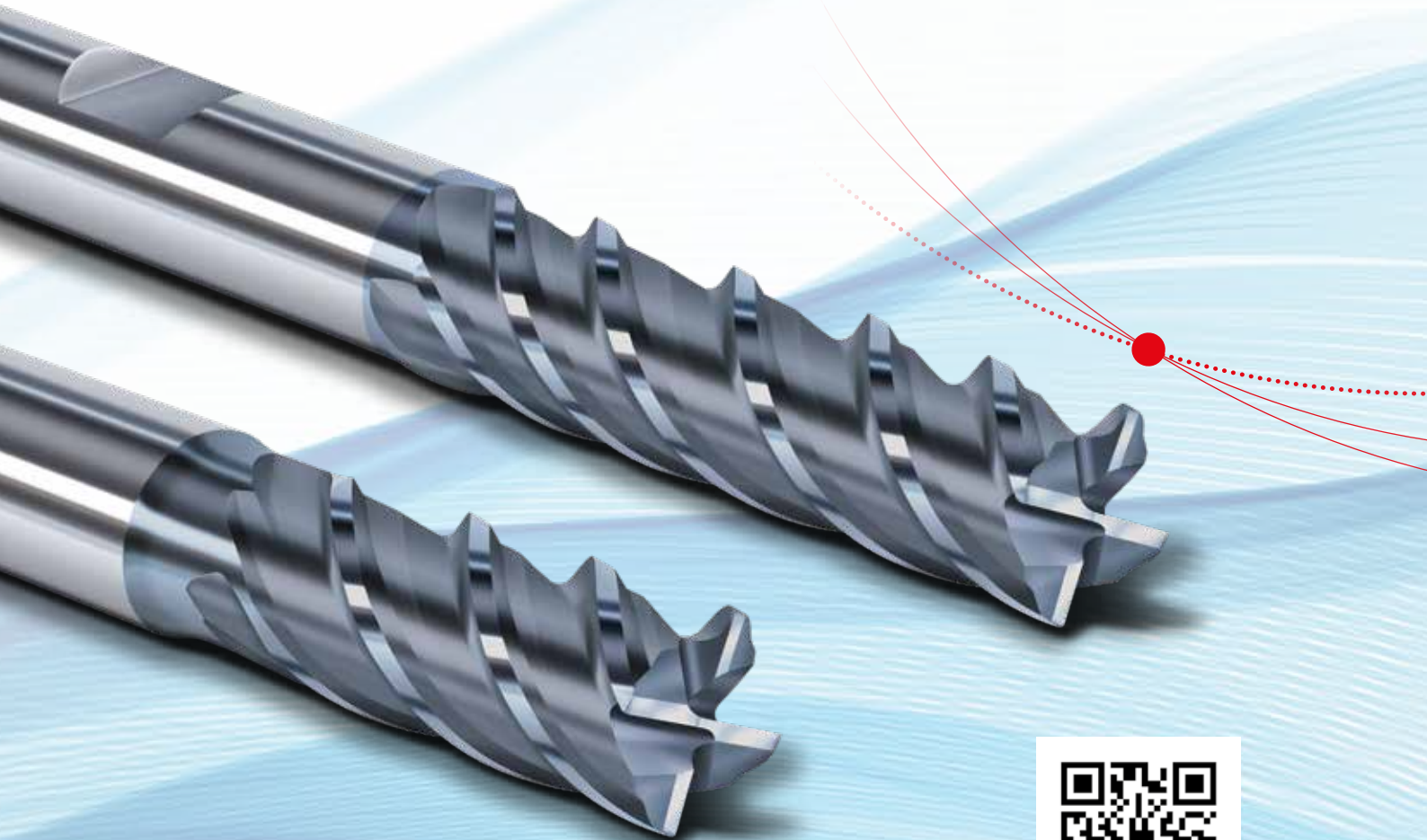

Designed to run –  
**the new Favora<sup>®</sup> tool concept**



**FRAISA**  
**ToolExpert<sup>®</sup>**

# High-performance technologies for the **Favora®** class

The **Favora®** class stands for maximum cost-effectiveness. By cleverly integrating the very latest production technologies, we have succeeded in **extending tool life by 50% compared to the predecessor model** without increasing production costs.

Trust is important to FRAISA. The new **Favora®** tool portfolio has been tested intensively under real-life conditions in a wide range of materials and with a wide variety of application parameters. In this way, we were able to determine **perfect cutting data** – which you can call up in FRAISA ToolExpert®. Another new feature: The optimized geometry of these tools now also allows you to follow the High Dynamic Cutting strategies **HDC-S** and **HDC-P**.

[ 2 ] The new milling concept, for diameters between 1 mm and 20 mm, can cover a very wide range of applications and components. After use, the tools can be restored to their original condition and performance capabilities by the **FRAISA ReTool®** reconditioning service. This FRAISA service has also been validated by the test center, which conducted appropriate machining tests.

The new **Favora®** tools stand out thanks to their **great universality, performance, and tool life** – making them **unbeatably economical**.

## The advantages:

- **Outstanding cost-effectiveness**  
50% longer tool life than the previous **Favora®** tools
- **Comprehensive range with catalog and cutting data in FRAISA ToolExpert®**  
Diameters ranging from 1 mm to 20 mm; two different lengths: standard and medium-long
- **New application areas** for HDC machining – cutting data in FRAISA ToolExpert®
- **Ideal life cycle** with FRAISA ToolCare® tool management, **FRAISA ReTool®** tool reconditioning, and FRAISA ReToolBlue tool recycling

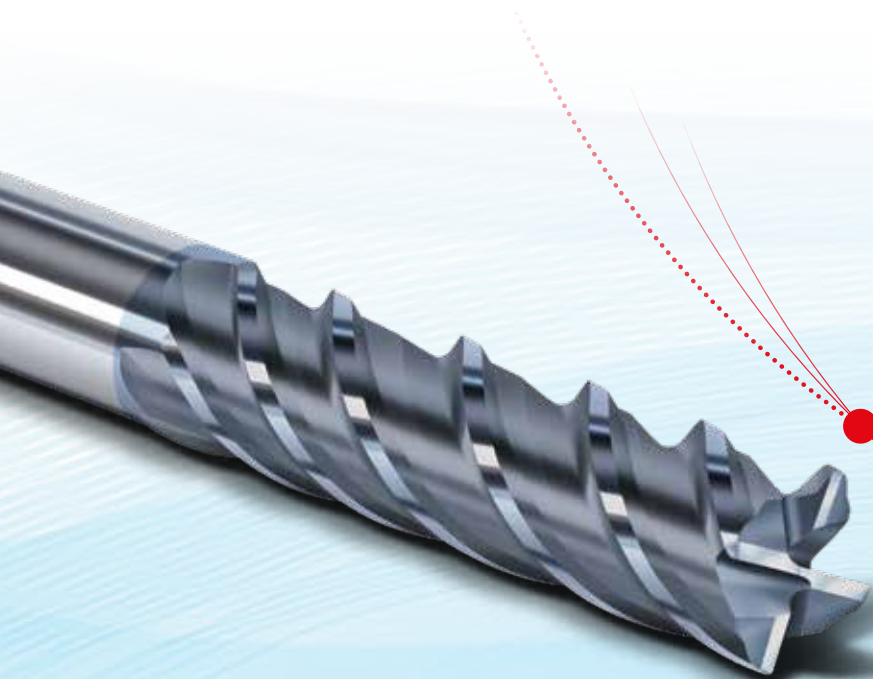

# The technologies behind the new Favora® tools

Dependable technologies cleverly combined: The new Favora® tools feature a number of high-tech technologies such as edge conditioning, which produces extremely smooth cutting edges, and optimized tooth polishing, which ensures an exceedingly

robust cutting edge and nearly flawless chip removal. Thanks to new grinding strategies and improved manufacturing processes, these can now also be utilized for Favora® tools – without any impact on the price.

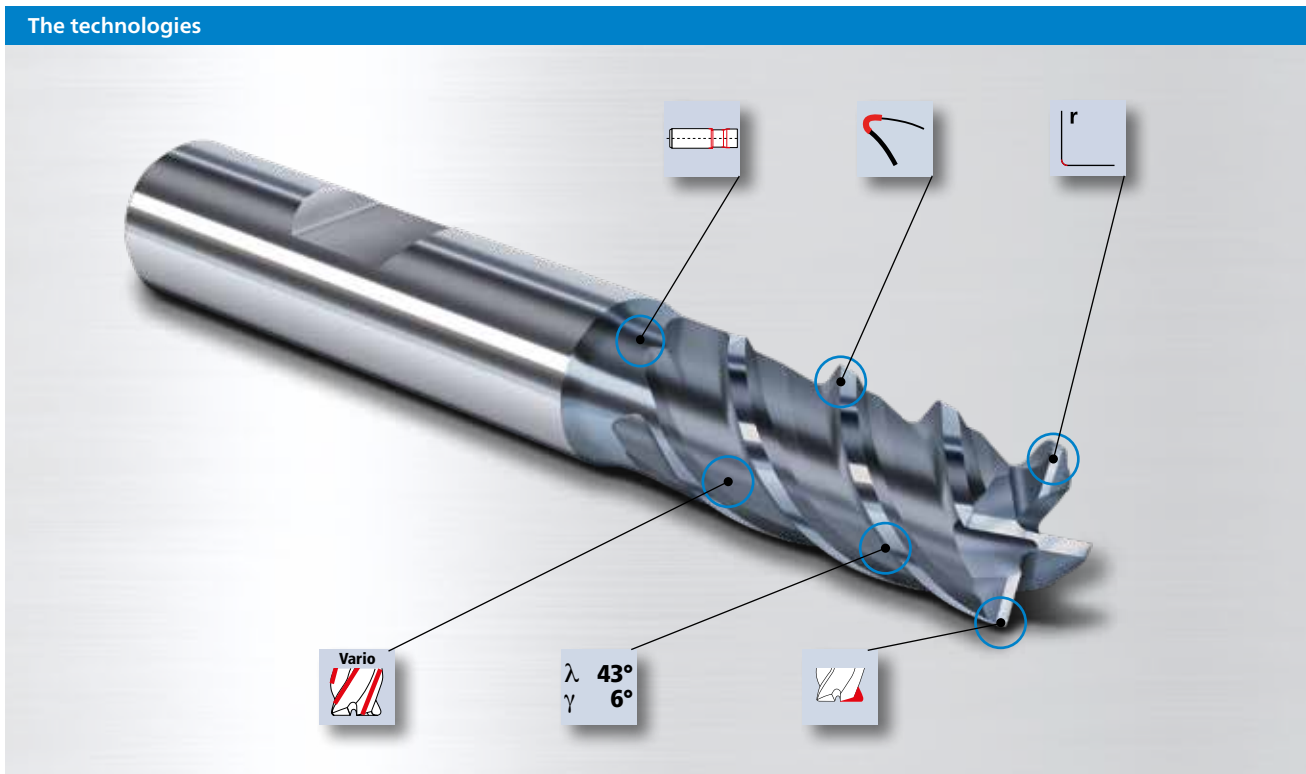

[ 3 ]

 **Milling tool with a partially polished blade**

- Reinforcement of the exposed cutting corner
- Absorption of high cutting forces

 **Small corner radius**

- The cylindrical tool has a small corner radius to strengthen the cutting edge
- Higher thermal and mechanical loads are possible and can be transformed into improved performance

 **Smooth transitions**

- The shaft-neck-cutting edge transitions are fitted with smooth gradients and radii
- Improved tool rigidity and therefore less radial deflection
- Minimal step formation with several infeed depths
- Higher mechanical load and therefore improved performance

 **Milling tool with special edge conditioning**

- Conditioning of the main cutting edge for increased stability
- Increase the mechanical and thermal load on the cutting edge
- General increase in the tool life

 **Milling tool with a variable helix angle**

- Minimisation of oscillation and vibrations
- Increase in material removal rates and tool life

# 50% longer tool life guarantees maximum cost-effectiveness

The tool life of these new **Favora**<sup>®</sup> tools is impressive: Compared to the reliable P45317 and P45322 tools, tool life can be extended by an additional 50%. The following photos show the conventional version of **Favora**<sup>®</sup> after 50 minutes machining and the new version of the tool after 75 minutes. If you look closely, you'll see that the new tool has actually worn slightly less.

50% longer tool life	
Conventional Favora <sup>®</sup>	New Favora <sup>®</sup>
P45317.450	P46300.450
Diameter: 10 mm	Diameter: 10 mm
Material: 1.0570	Material: 1.0570
Cutting strategy: HPC	Cutting strategy: HPC
$v_c$ 140 m/min; $f_z$ 0.068 mm; $a_p$ 15 mm; $a_e$ 4 mm	$v_c$ 140 m/min; $f_z$ 0.068 mm; $a_p$ 15 mm; $a_e$ 4 mm
Cutting time: 50 min	<b>Cutting time: 75 min</b>

**+50%**

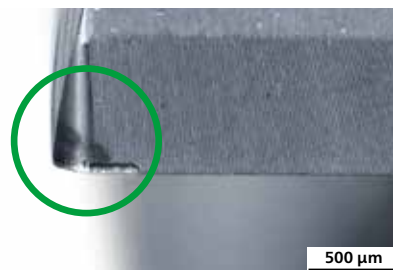

[ 4 ]

# New potential applications – proven cutting data in all strategies

The new **Favora**® tools can be put to use in a whole variety of applications. FRAISA has invested considerably in the development of these tools and in validating the cutting data for the various milling strategies. Thanks to this investment, the tools cover the entire range spectrum of 2.5D machining strategies.

Workpiece material: 1.2738

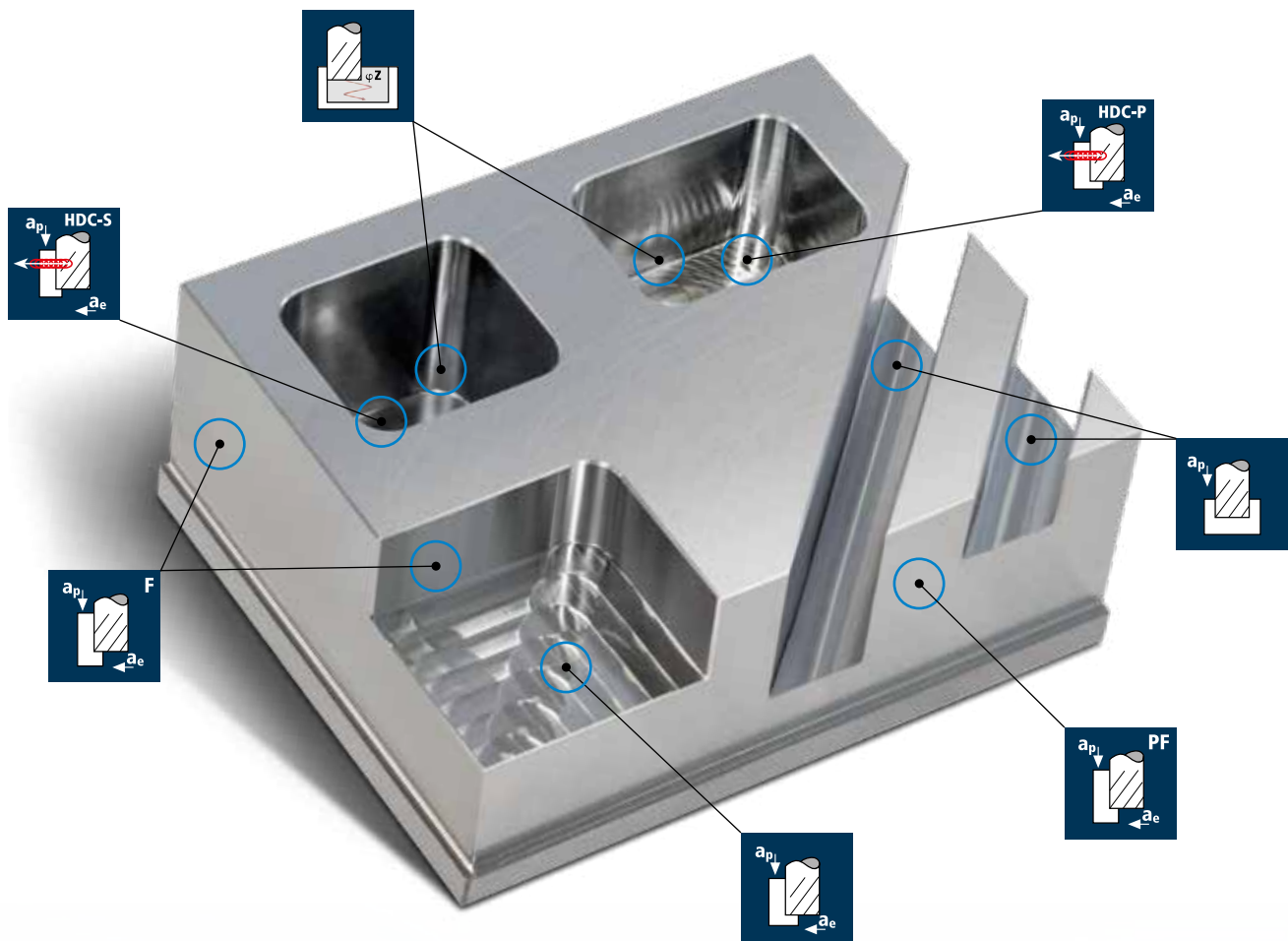

[ 5 ]

Detailed descriptions of each application can be found in our “High-performance milling tools” catalog.

## Cutting data

The cutting data for the applications “Lateral HPC (partial cut)” and “Flutes in HPC (full cut)” in combination with the new **Favora**® tools can be found as always in the catalog. All other applications are available online in **FRAISA ToolExpert**®.



# Cylindrical end mills

Smooth-edged, normal version, short neck



**HM**  
**MG10**     $\lambda$  **43°**  
                   $\gamma$  **6°**

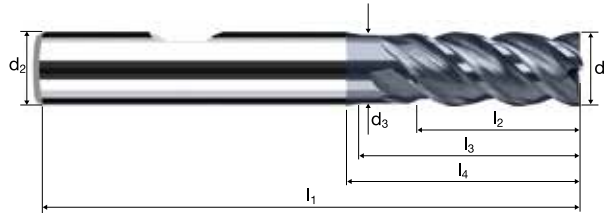

Roughing HPC    Roughing HDC    Finishing

Rm < 850    Rm 850-1100    Rm 1100-1300    **Inox** Stainless    Ti Titanium    GG(G) Tool Steel Nickel-Alloys

Example: Order-N°.											POLYCHROM	
											P46300	
											P46200	
Ø Code	d <sub>1</sub> e8	d <sub>2</sub> h6	d <sub>3</sub>	l <sub>1</sub>	l <sub>2</sub>	l <sub>3</sub>	l <sub>4</sub>	r	α	z		
100	1.00	6.00	0.95	57	3.00	7.00	16.82	0.050	9.0°	4	●	
140	2.00	6.00	1.90	57	5.00	10.00	18.05	0.050	6.5°	4	●	
178*	3.00	3.00	-	45	8.00	-	-	0.050	0.0°	4	●	
180	3.00	6.00	2.80	57	8.00	14.00	20.37	0.050	4.5°	4	●	
218*	4.00	4.00	-	50	11.00	-	-	0.100	0.0°	4	●	
220	4.00	6.00	3.70	57	11.00	16.00	20.82	0.100	3.0°	4	●	
258*	5.00	5.00	-	50	13.00	-	-	0.100	0.0°	4	●	
260	5.00	6.00	4.60	57	13.00	18.00	21.27	0.100	1.5°	4	●	
300	6.00	6.00	5.50	57	13.00	18.15	20.00	0.150	0.0°	4	●	
391	8.00	8.00	7.40	63	19.00	23.63	26.00	0.150	0.0°	4	●	
450	10.00	10.00	9.20	72	23.00	27.99	31.00	0.200	0.0°	4	●	
501	12.00	12.00	11.00	83	27.00	33.29	37.00	0.200	0.0°	4	●	
570	14.00	14.00	13.00	83	28.00	32.97	37.00	0.200	0.0°	4	●	
610	16.00	16.00	15.00	92	32.00	38.73	43.00	0.200	0.0°	4	●	
682	20.00	20.00	19.00	104	40.00	48.23	53.00	0.250	0.0°	4	●	
* without clamping flat only, without short neck												

[ 6 ]

# Cylindrical end mills

Smooth-edged, medium length version



HM  
MG10

$\lambda$  43°  
 $\gamma$  6°

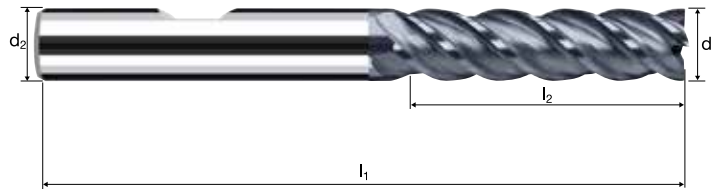

Roughing HPC    Roughing HDC    Finishing



Rm < 850    Rm 850-1100    Rm 1100-1300    Incoating    Ti Titanium    GG(G) Tool Steel Nickel-Alloys

Example: Order-N°.										POLYCHROM	
										P46310	
										P46210	
$\emptyset$ Code	d1 e8	d2 h6	l1	l2	l4	r	$\alpha$	z			
140	2.00	6.00	63	12.00	21.42	0.050	6.0°	4			●
160	2.50	6.00	63	12.00	20.49	0.050	5.0°	4			●
180	3.00	6.00	63	13.00	20.56	0.050	4.5°	4			●
220	4.00	6.00	63	13.00	18.89	0.100	3.5°	4			●
260	5.00	6.00	63	16.00	20.02	0.100	1.5°	4			●
300	6.00	6.00	63	21.00	-	0.150	0.0°	4			●
391	8.00	8.00	72	31.00	-	0.150	0.0°	4			●
450	10.00	10.00	84	37.00	-	0.200	0.0°	4			●
501	12.00	12.00	97	44.00	-	0.200	0.0°	4			●
570	14.00	14.00	102	48.00	-	0.200	0.0°	4			●
610	16.00	16.00	108	53.00	-	0.200	0.0°	4			●
682	20.00	20.00	122	62.00	-	0.250	0.0°	4			●

[ 7 ]

## FRAISA ReTool® – Industrial tool reconditioning with performance guarantee



FRAISA ReTool® offers an all-round service that restores your used tools to their original performance level and optimizes your processes. FRAISA and third-party tools are reconditioned using the very latest technology – and in a resource-friendly way. The outcome: mint-condition tools as productive as they were the first day they were used. And to make things even better, your level of investment is lower than if you were to buy new tools, you increase your productivity and you save costs.

### Over 30 years' experience in tool reconditioning:

Our competence center in Germany is Europe's largest service center for carbide milling tools.



Video on our service product: FRAISA ReTool®



Scan this QR code to find more information on the FRAISA Group.



The fastest way to our E-Shop.

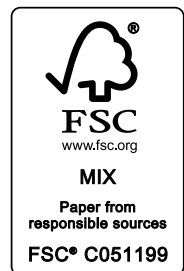

**FRAISA SA**

Gurzelenstr. 7 | CH-4512 Bellach | Switzerland |  
Tel.: +41 (0) 32 617 42 42 |  
mail.ch@fraisa.com | fraisa.com |

You can also find us at:

**facebook.com/fraisagroup**  
**youtube.com/fraisagroup**  
**linkedin.com/company/fraisa**

passion  
for precision



HIB02030 02/2022 EN