

passion  
for precision



Designed to run  
**+50% tool life**

**FRAISA** – Your technology partner for  
milling processes

Article P46300/P46200 and P46310/P46210

## The new **Favora**<sup>®</sup> tool concept

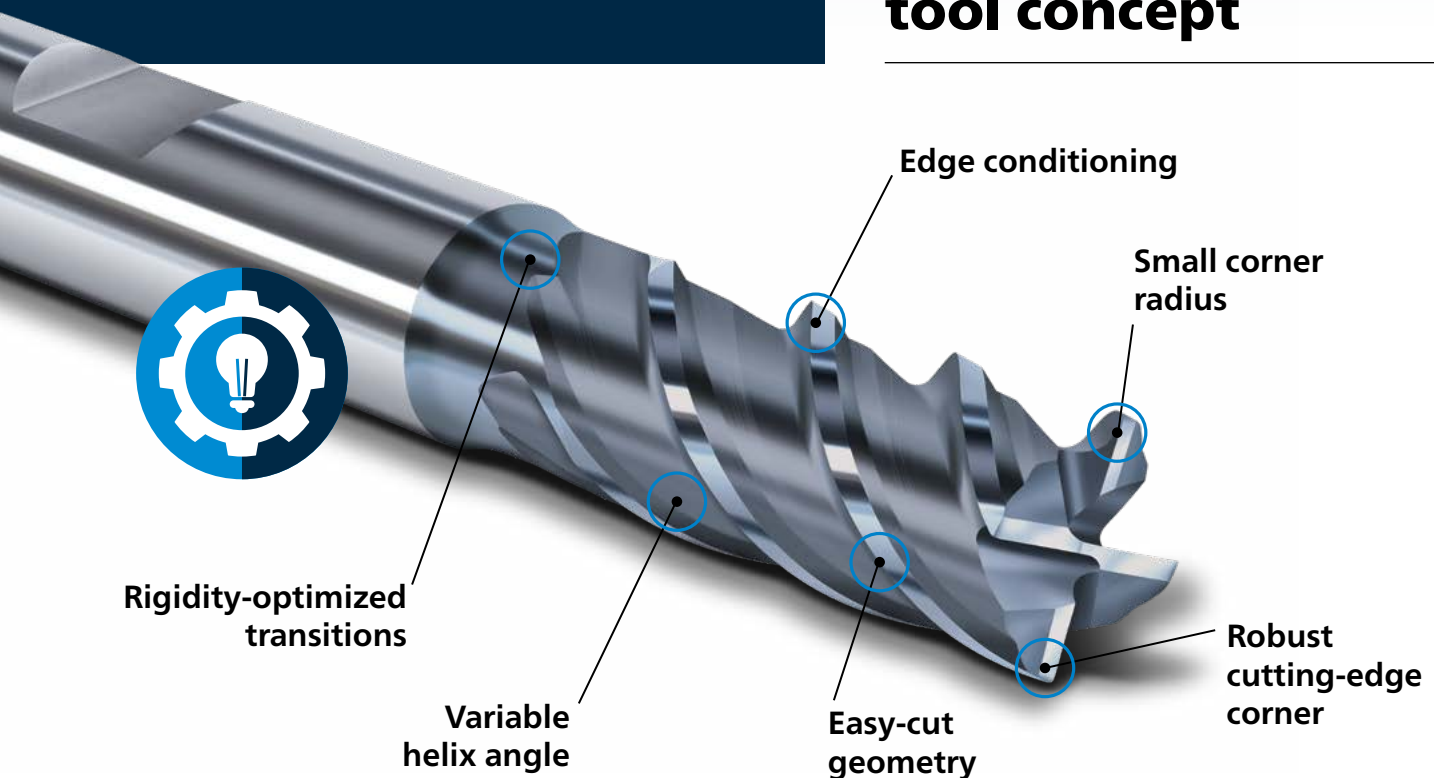

**50% longer tool life**

**Universal use**

**Comprehensive range**

**Sustainable thanks to FRAISA ReTool<sup>®</sup>**

**Extremely economical HPC and HDC-capable**

**Verified application data**



**Further information**

FRAISA Group  
fraisa.com